



Owner's Manual



Dogtra Company

22912 Lockness Avenue

Torrance, CA 90501 U.S.A.

Tel) 310.534.0101

Fax) 310.534.9111

Toll Free) 1.888.811.9111

Store website) shop.dogtra.com

Copyright © 2007 Dogtra Company All rights reserved. (5)

Remote Controlled Dog Training Collars

***dogtra* 2500T&B Series**



www.dogtra.com

• OVERVIEW	3
• MAIN FEATURES	5
• PRODUCT SAFETY AND HEALTH STATEMENTS	7
• PACKAGE CONTENTS	8
• DESCRIPTION OF TRANSMITTER PARTS	9
• BUTTON FUNCTION.....	19
• DESCRIPTION OF COLLAR/RECEIVER PARTS	25
• BATTERY CHARGER	29
• TESTING YOUR dogtra 2500 T&B	30
• TESTING YOUR dogtra 2502 T&B	34
• FITTING THE COLLAR ON THE DOG	35
• CHARGING THE BATTERIES	38
• RECEPTION	41
• ACCESSORIES	42
• BASIC MAINTENANCE	43
• TROUBLESHOOTING GUIDE	44
• WARRANTY AND REPAIR INFORMATION	47

THANK YOU FOR PURCHASING THE WORLD'S FINEST E-COLLAR

***dogtra* 2500 T&B** Beeper Collar

The ***dogtra* 2500 T&B Series** remote training system will give you the ability to keep track of your dog's location when he/she is out of sight or on point.

The ***dogtra* 2500 T&B Series** is also a training collar that can be used for behavior management.

The Dogtra training & beeper collars are waterproof, lightweight, and reliable. They are built to withstand the most rugged conditions that your dog may encounter.

The beeper has an audible 400-yard range, which may vary with tough terrain and wind conditions.

The use of microcomputer technology, digital circuitry and Lithium-Polymer batteries make both the collar and transmitter compact and very reliable.

OVERVIEW

The ***dogtra* 2500 T&B Series** features nick and constant stimulations, which can be controlled from the transmitter. Turning the knob on the top of the transmitter adjusts the intensity of the stimulation. The LCD screen will display the intensity level on the front of the transmitter (0 thru 127). It also has a remote beeper with three different modes. To activate the transmitter, press and hold the blue button on the right side of the transmitter until both the LCD and LED window illuminates. Next, hold the two red dots on the transmitter and receiver together until the receiver light starts blinking. The receiver/collar's LED window will blink green every 4 seconds to show that the unit is on and fully charged.

Your ***dogtra* 2500 T&B** has three beeper modes: Run/point, Point-Only, and Locate. Locate is available anytime by pressing the top orange button on the left side of the transmitter. To activate the other beeper modes, press the MODE button on the side of the transmitter. The first time you press the MODE button, the collar will beep twice. The beeper unit is now in the Run/Point mode. The beeper will always start in this mode, but can easily be changed to the Point-Only mode by pressing the MODE button a second time. In the Run/Point mode, it will double beep every 7 seconds while the dog is running. When the dog is on point or stationary

it double beeps every 2 seconds. By pushing the MODE button a second time, the unit will go into the Point-Only mode. While the dog is moving, the unit will not beep, (you can use the Locate mode for locating your dog). When the dog points or becomes stationary, the unit will emit a double beep every 2 seconds. The Locate feature can be used at any time, it will beep as long as you press and hold the button. To turn the beeper unit off, press the MODE button a third time. The unit will emit three rapid beeps, thereafter; the unit will be turned off. Remember, the Locate button can still be used at any time!!

There are two beeper tones: High and Low. The tone of the beeper can be selected with a toggle switch located on the transmitter. The beeper volume for the Run/Point mode and Point-Only modes can be increased or decreased by holding the Locate button down while pressing the Mode button abruptly.

*Please refer to page 22 & 23 for a detailed chart on Mode and Beeper Volume level variations.

The **dogtra 2502 T&B** is a two-dog model. The collars are color-coded (green and orange) you can select between the two collars with a toggle switch located on the transmitter.

The orange collar emits a low-tone double beep in all modes and the green collar emits a high-tone single beep in all modes. This gives you the ability to differentiate between dogs when both are out of sight.

MAIN FEATURES

- Easy-to-use, ergonomically fitted transmitter.
- Rheostat dial that allows for gradual adjustments in stimulation intensity with no jumps between levels (0-127 levels).
- Two-dog models allow the trainer to control two different dogs from one transmitter.
- The **dogtra 2500 T&B Series** has a 1-mile range.
- 2 different stimulation types - “Nick” & “Constant”
- 400-yard audible remote-controlled beeper.
- The freedom to choose between a High and Low tone beeper. (Single-dog unit only)
- Three beeper modes - “Run & Point”, “Point”, and “Locate”.
- **dogtra 2500 T&B Series** features a new, innovative, Beeper Volume Control. You may now select between 2 different tones and 3 volume levels for each tone.
- **dogtra 2500 T&B Series** combines the receiver with the beeper horn into one small, compact unit.
- **dogtra 2500 T&B Series** uses Lithium Polymer batteries that provide a 2-hour rapid charge.

- Fully waterproof collar/receiver and transmitter.
- No bothersome external antenna on the collar/receiver.
- One-charging system allows the transmitter and receiver(s) to be charged at the same time.
- Over 8000 different identity codes to prevent signal match-up with other e-collars.
- Easily visible blue LCD screen displays the exact level of stimulation and can even be seen clearly in the dark.
- A Three bar battery life indicator and LED colored indicator to show the remaining battery life.

PRODUCT SAFETY AND HEALTH STATEMENTS

Proper e-collar use

Dogtra e-collars are intended for the sole purpose of behavior modification of dogs. They are not intended for human use or use on other animals. Dogtra Company does not assume any liability for improper use of the Dogtra e-collar.

Aggressive dogs

Dogtra does not recommend using the e-collar to correct dogs that are aggressive towards other dogs or people. In many such cases the dog will associate the stimulation with the other dog or individual and become even more aggressive. Dog aggression is best treated by a dog-training specialist.

Interference with other electronic devices

Dogtra's industry-leading technology filtering system ensures minimal interference with other electronic devices (garage door openers, pacemakers, etc.). Our digital microprocessor offers thousands of unique codes to eliminate frequency match-up with other Dogtra e-collars.

Inadvertent activation

If the constant button is held down for 12 seconds or more the unit will automatically shut down. It will reactivate when the button is released.

PACKAGE CONTENTS

- Transmitter
- Receiver (two collar/receivers for Dogtra two-dog models)
- Lithium Polymer Battery charger and splitter cable
- Test light
- Owner's manual
- Carrying case
- Metal belt clip accessory

DESCRIPTION OF TRANSMITTER PARTS

dogtra 2500 T&B transmitter (1-dog)

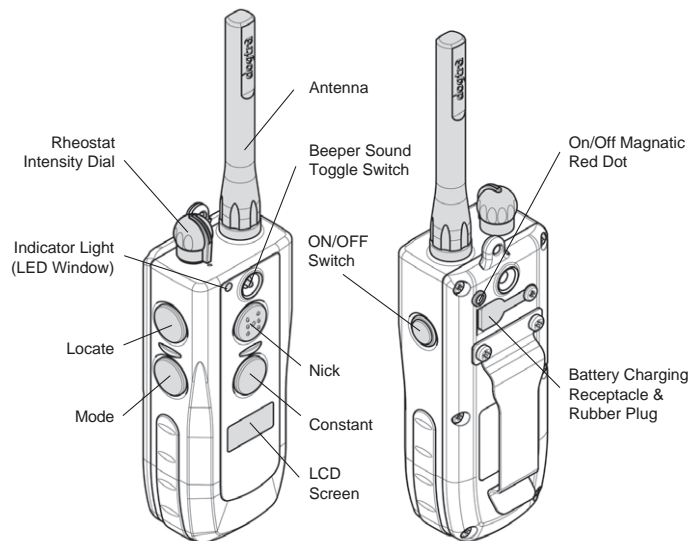

DESCRIPTION OF TRANSMITTER PARTS

dogtra 2502 T&B transmitter (2-dog)

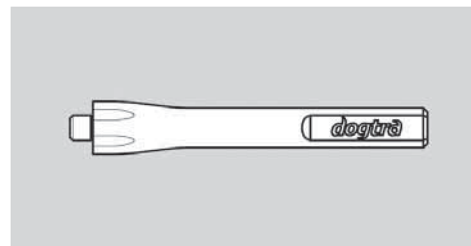
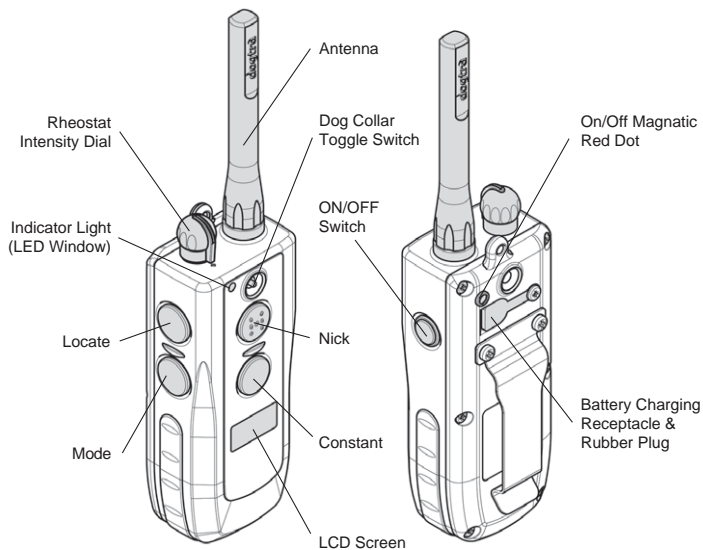

Transmitter Antenna

A 3.2" antenna is supplied with the *dogtra* 2500 T&B Series transmitter.

The antenna must be fastened to the transmitter before using the unit.

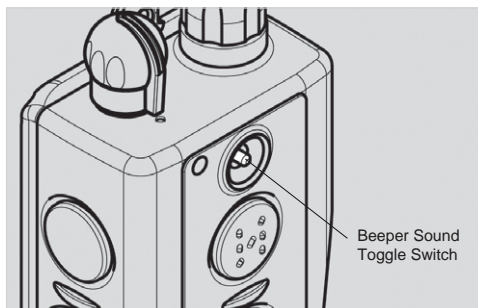

Beeper Sound Toggle Switch on the *dogtra* 2500 T&B One-Dog Models

The one-dog model has a Beeper Sound toggle switch on the face of the transmitter located above the “Nick” button, which is designed to easily select a beeper tone, either High or Low.

Set the toggle switch on the High position to select the High tone and the Low position to select the Low tone.

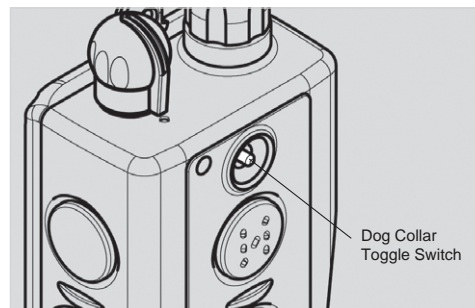

Dog Collar Toggle Switch on the *dogtra* 2502 T&B Two-Dog Models

The two-dog model has a toggle switch on the face of the transmitter located above the “Nick” button. The toggle switch allows for selection of either collar.

Set the toggle switch on the Green position to select the Green collar and the Orange position to select the Orange collar.

Stimulation (Nick and Constant) along with the beeper and locate modes will only operate when the toggle is in the desired position for the appropriate receiver/collar.

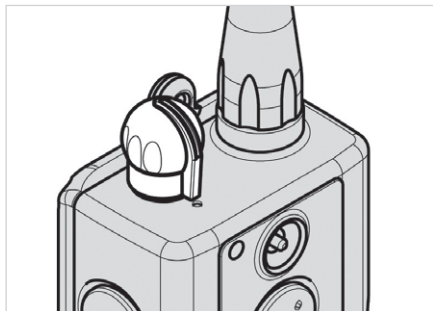

Rheostat Intensity Dial

The Rheostat Intensity Dial is located on the top of the transmitter: (0) being the lowest level and (127) being the highest. The LCD screen on the transmitter indicates the intensity level and battery life.

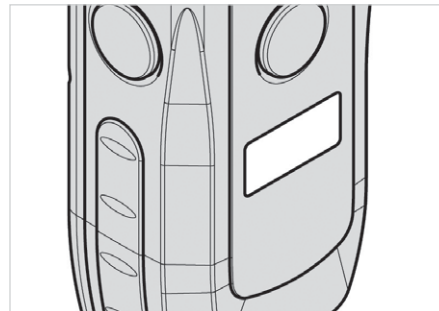

LCD Screen

The LCD screen indicates the stimulation level on the screen ranging from (0-127). The battery life indicator shows: 3 bars = full charge, 2 bars = medium charge, and 1 bar = needs charge.

When pressing the MODE button, the selected beeper volume level is shown on the LCD. (NOTE: Pressing the MODE button once will also set the unit in the Run/Point mode.) When the toggle switch is set on low tone the LCD will read: L1= lowest volume, L2 = medium volume and L3 = highest volume. When the toggle switch is set on high tone, the LCD will read: H1 = lowest volume, H2 = medium volume and H3 = highest volume.

Care for LCD Transmitters in Cold Temperature

In cold temperatures (10 degrees F or below), the Liquid Crystal Display (LCD) on your transmitter may be dim or slow to respond. Wait until the display becomes visible before selecting any training level.

Even though the LCD screen might be dim or slow to respond when you push the Nick or Constant button, the transmitter will still function properly. In the occurrence of extremely cold weather, the LCD screen might take a moment to respond causing the intensity level to freeze at that current level. In this situation, if you turn the rheostat intensity dial, the level on the screen may not change but the actual intensity from the collar/receiver will change in agreement with the dial.

In this situation, it is ideal to either wait until your transmitter is back to working order before emitting a correction, or while holding the constant button down slowly turn the Rheostat Intensity Dial while watching your dog's reaction. Do not turn the Rheostat Intensity Dial at a rapid increase because the collar/receiver will emit a static correction based on the level of the Rheostat Intensity Dial, which might not be correctly reflected on the LCD screen.

Suggestion: Carry your remote close to your body as your body's warmth can improve operation and viewing of the LCD screen.

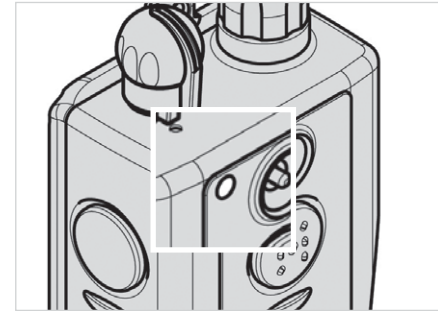

Transmitter Indicator Light (LED Window)

The transmitter LED indicator light is located near the Rheostat Intensity Dial. It will flash every 4 seconds when the transmitter has been turned on. The color of the light indicates the status of battery life. It flashes green when the battery is fully charged and turns to amber when the battery is at medium charge. It is acceptable to charge your unit even at medium charge without any damage incurred to your collar. When the transmitter indicator emits a blinking red light, the battery needs to be recharged.

(Green = full charge, Amber = medium charge, Red = needs charge)

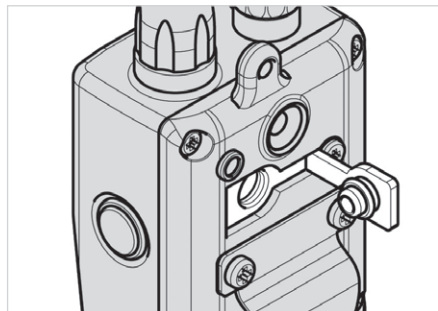

Transmitter Battery Charging Receptacle & Rubber Plug

Located on the backside of the transmitter, the charging receptacle is covered by a rubber plug. Insert one end of the battery charging cable into the receptacle to charge the battery. (See Battery Charging Procedure on page 38~40.)

After charging is completed, close the receptacle with its rubber plug to make sure dirt or water does not get inside.

*** The unit will be fully waterproof with or without the rubber plug.**

BUTTON FUNCTION

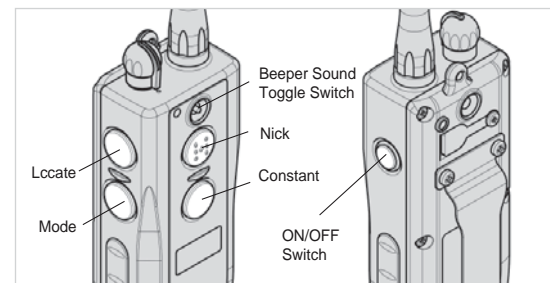

The transmitter for the *dogtra 2500 T&B Series* has five buttons.(two on the face of the transmitter, two on the left side, and one on the right side.)

“Nick” Button

When the “Nick” button is pushed, the receiver emits a single rapid pulse of electrical stimulation.

“Constant” Button

Pressing the “Constant” button gives continuous stimulation as long as the button is pushed, for up to 12 seconds. If the button is not released after 12 seconds, the stimulation will automatically turn off as a safety feature. The collar will be ready to be reactivated once the button has been released.

“Locate” Button

The “Locate” button is located on the left side. It causes the collar’s beeper horn to emit a series of beeps when pushed and it gives you the ability to keep track of your dog’s location. On one-dog models, the beeper can be adjusted between high and low tones. NOTE: The high/low tone is not an option on two dog units.

On two-dog models, the Green collar emits the high tone and the Orange collar the low tone automatically.

“Mode” Button

Your Dogtra 2500T&B has three different modes. Locate, Run/Point, and Point-Only. The “LOCATE” mode can be activated at any time, even when another mode is set, by pressing the

top orange button labeled “LOCATE” on the left side of the transmitter. To set the beeper unit to Run/Point mode, press the orange “MODE” button. This button is located on the left side of the transmitter, under the “LOCATE” button.

When you press the “MODE” button the first time, the collar will beep twice. The beeper unit will always start in Run/Point mode. It is now in Run/Point mode. The beeper will sound every 7 seconds while the dog is running, and every 2 seconds when the dog is gone on point or become stationary.

The second time you push the “MODE” button, it will beep once, remain silent while the dog is running and beep every 2 seconds when the dog is on point or stationary.

To turn the beeper unit off, press the MODE button a third time. The unit will emit three rapid beeps, and the beeper will turn off. The Locate mode can still be used!

When the toggle switch is set on Low tone, the beeper will emit a double beep when it is in Run/Point mode or Point-only mode. If the toggle switch is set on the High tone, a single beep will sound when using Run/Point or Point-Only mode.

	Initial Beeper Sound	Mode	Action
Press 1 st Time	2 Beeps	Run/Point Mode	-Dog running: Double beep every 7 seconds. -Dog on-point: Double beep every 2 seconds.
Press 2 nd Time	1 Beep	Point-Only Mode	-Dog running : Remains Silent. -Dog on-point : Double beep every 2 seconds
Press 3 rd Time	3 Beeps	Beeper	Unit Turned off

*** NOTE : The locate button can be used in any mode you are in.**

Beeper Volume Adjustment

The Beeper Volume level for the Run/Point mode and Point-Only mode can be increased or decreased by holding the LOCATE button down while briefly pushing the MODE button. The tone of the beeper can be selected with a toggle switch located on the face of the transmitter. There are two beeper tones: High (H1 = lowest volume, H2 = medium volume, and H3 = highest volume) and Low: (L1 = lowest volume, L2 = medium volume, and L3 = highest volume).

	Toggle Switch High LCD Displays	Toggle Switch Low LCD Displays
Press Mode Once (While holding down the locate button)	H 1	L 1
Press Mode 2 nd Time (While holding down the locate button)	H 2	L 2
Press Mode 3 rd Time (While holding down the locate button)	H 3	L 3

*** NOTE : The Locate mode beeper volume is not adjustable; it is always on the highest level, L3 on Low tone, or H3 on High tone.**

Transmitter Power ON/OFF

The button on the right side of the transmitter is the “ON/OFF” button that activates the transmitter and LCD screen only.

To turn the transmitter on, press the “ON/OFF” button on the right side until the LCD screen illuminates.

To turn the transmitter off, press the “ON/OFF” button on the right side of the transmitter. When the LCD screen displays “OFF” release the button.

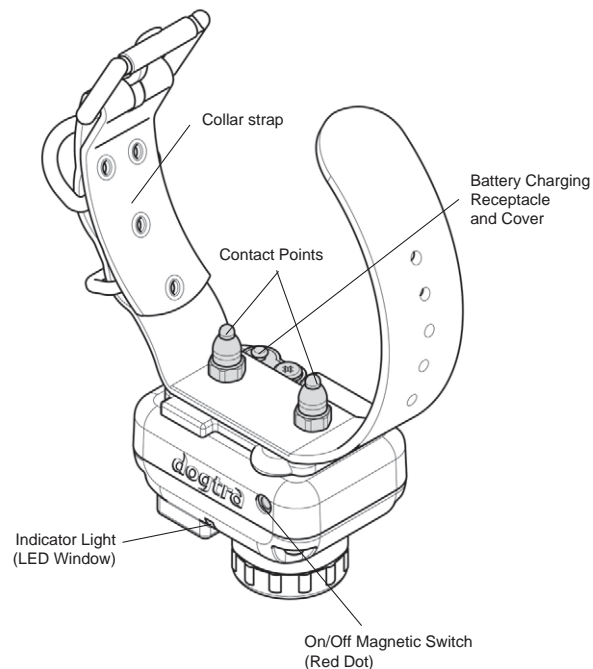
**DESCRIPTION OF
COLLAR / RECEIVER PARTS**

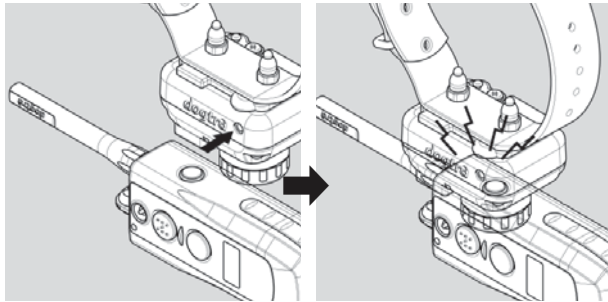

Receiver ON/OFF Magnetic Red Dot

To activate the receiver/collar, place the red dot on the back of the transmitter to the red dot on the collar/receiver. Hold the two red dots together for a moment until the LED light on the receiver/collar comes on.

To deactivate the unit, repeat the same procedure holding the two red dots together momentarily. The LED light will turn red for a brief moment indicating that the collar/receiver is now shut off.

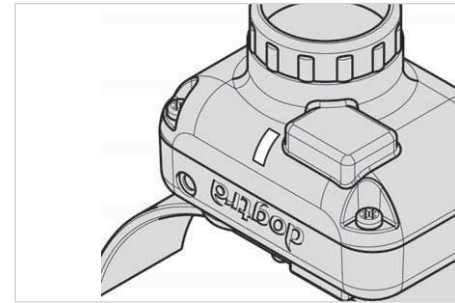

Receiver Indicator Light (LED window)

Located on the front of the receiver/collar, the indicator light comes on and blinks once every 4 seconds after the collar has been turned on. The color of the LED indicates the battery life of the receiver.

(**Green** = full charge, **Amber** = medium charge, **Red** = needs charge)

When the “Constant” button on the transmitter is pushed, the collar indicator light will glow steadily (either green, amber, or red based on the remaining battery life), as long as you hold the button down, for up to 12 seconds.

When the “Nick” button is pushed, the light comes on for a fraction of a second.

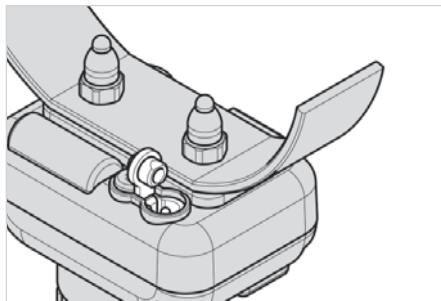

Receiver Battery Charging Receptacle and Rubber Plug

On the inside of the collar receiver, next to the collar strap, is a battery-charging receptacle with a rubber plug.

*** The unit will be fully waterproof with or without the rubber plug. If the dog was in salt-water, be sure to rinse the receiver and charging port with clean water, and let air dry.**

BATTERY CHARGER

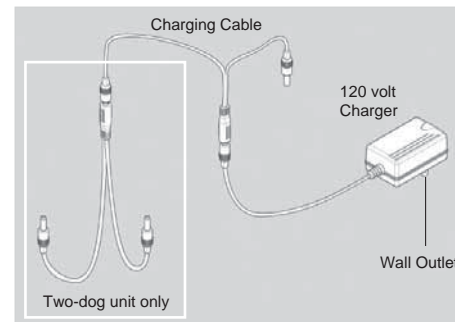

The battery charger and charging cables allow you to charge both the transmitter and receiver at the same time. The battery charger is designed for a 120-volt wall outlet. (European 230-volt AC chargers and 10-volt car charger for Lithium-Polymer batteries are also available.)

To use the battery charger for the two-dog unit, combine both sets of battery charging (splitter) cables as shown. This enables you to charge the transmitter and both receivers at the same time.

NOTE : Only use Dogtra-approved Lithium-Polymer Battery Chargers for your Dogtra e-collar. This will prevent any damage that can be incurred from attempting to use a different charger.

TESTING YOUR *dogtra* 2500 T&B Series COLLAR

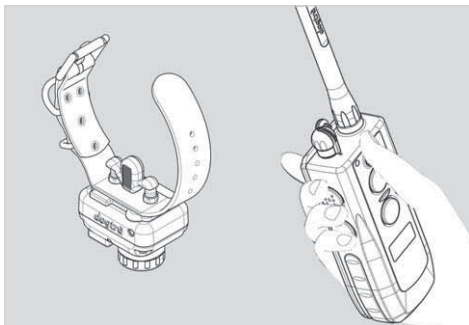

1. To activate the receiver/collar, place the red dot on the back of the transmitter to the red dot on the collar/receiver. Hold the two red dots together for a moment until the LED light on the receiver/collar comes on. The indicator light will come on for a moment then blink once every 4 seconds, showing that the collar is ready to use. (If the indicator light is red, or if there is only 1 bar showing on the battery icon on the LCD transmitter screen, the unit needs to be charged.)

2. Place the test light, included in the package contents, on the contact points as shown in the diagram.
3. Turn the transmitter on by pressing the blue button on the right side of the transmitter until the LCD screen illuminates. The LCD screen shows the amount of battery life remaining and the LED blinks once every 4 seconds.
4. Watch the test light as you push the “Nick” button on the transmitter. It should light for just a moment. The higher the intensity, the brighter the test light will be.
5. Watch the test light as you push the “Constant” button on the transmitter. It should light for as long as the button is pressed. However, as a safety feature, the collar/receiver will automatically stop stimulation if the constant button is depressed for 12 seconds or longer.
6. Turn the Rheostat Intensity Dial on the transmitter clockwise and then counterclockwise. The test light should glow brighter with higher levels of stimulation and dimmer with lower levels. When you change the intensity dial, the number on the LCD screen will change as well.

NOTE : The test light may not be visible if the intensity level is set below level ten.

7. To make sure that your beeper is working properly, press the Locate button once with the horn portion facing away from you (or place your hand over the horn). The sound may be extremely loud and may cause discomfort to your ears. If you do hear an audible beeper sound, your location button is in working order.
8. Press the Mode button once; you should hear 2 rapid beeps. This will put you into the Run/Point Mode. Keep the receiver/collar steady to mimic your dog at a standstill point. Wait for a moment until you hear a double beep in 2-second intervals. You may proceed to the next step if the double beep occurs.
9. Press the Mode button a second time; you should hear 1 rapid beep. This will put you into the Point-Only Mode. Once again, keep your receiver/collar steady and wait for a moment until the collar emits a double beep every 2 seconds. If it is audible, move onto the next step.
10. Press the Mode button a third time; you should hear 3 rapid beeps. This mode will turn off your beeper and remain silent.

NOTE 1 : The sound that the beeper will emit will vary depending on your selection with the (High/Low) toggle switch. The two-dog model: Dogtra 2502 T&B has a fixed beeper sound based on the color of the collar.

NOTE 2 : When using the Run/Point mode or the Point-Only mode, the beeper volume level reverts back to the volume level that was last used.

NOTE 3 : In the Run/Point or Point-Only mode the tone can be changed by holding down the “Locate” button and then pressing the “Mode” button when the High/Low toggle switch is in the desired position. The unit must be activated and in the Run/Point or Point-Only mode first.

NOTE 4 : In the Run/Point or Point-Only mode it is still possible to use electrical stimulation.

*** To make sure that your Beeper Volume is in working condition, please refer to page 23 for further testing instructions.**

TESTING YOUR *dogtra* 2502 T&B

The Dogtra 2502 T&B two-dog unit operates just like the Dogtra 2500 T&B single-dog unit. The difference between the one-dog and two-dog collar is noticeable on the transmitter where a toggle switch allows you to select either collar.

The toggle switch is color-coded with green and orange to match the green and orange collar straps. The orange collar emits a low tone double beep and the green collar gives a high tone single beep so you can distinguish between dogs when they are out of sight.

The two-dog models have a toggle switch on the face of the transmitter located above the “Nick” button. The toggle switch allows for selection of either collar.

Set the toggle switch on the orange position to select the orange collar and the green position to select the green collar.

Orange Collar : Double beep with low tone
Green Collar : Single beep with high tone

FITTING THE COLLAR ON THE DOG

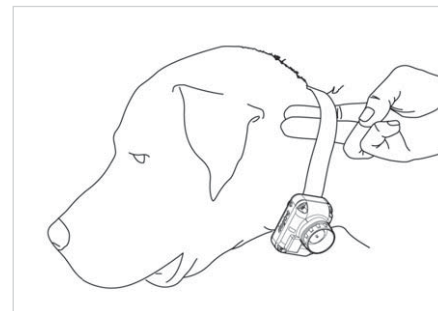

PROPER FIT

The collar should be fitted so that the surgical stainless steel contact points press firmly against the dog's skin. You should be able to fit a finger in between the contact point and your dog's skin. The best location is either side of the dog's windpipe.

IMPROPER FIT

A loose fit can allow the collar to move around on the dog's neck. When this happens, the contact points may rub against the skin and cause irritation. If the collar is too loose, electrical contact will be inconsistent causing your corrections to be inconsistent.

Dogtra uses surgical stainless steel contact points and anti-microbial plastic to protect the dog's skin.

ATTENTION!

Leaving the collar/receiver in the same location on the dog's neck, for an extended period of time can cause skin irritation. If the dog is to wear the e-collar for long periods, occasionally reposition the collar so that the contact points are moved to a different location on the dog's neck. Make sure you check for skin irritation, each time you use the unit.

INTENSITY SELECTION

The **dogtra 2500 T&B Series** has a Rheostat Intensity Dial on the top of the transmitter (0 is the lowest and 127 is the highest). Remember that you will need to adjust the setting (upward or downward) depending on your dog's temperament and threshold for stimulation. Also, as the dog's attitude changes, especially during times of increased excitement or distraction, you may need to adjust the intensity level.

NOTE : The stimulation intensity can be adjusted even while the stimulation is in use.

FAMILIARIZING THE DOG TO THE BEEPER SOUND

Turn the beeper collar on and leave it outside the dog's kennel area for about a half-hour.

Repeat this several times, until you can see that the dog disregards the beeper.

Next, adjust the beeper volume level to level L1, the lowest level. Fit the beeper collar on the dog. Select the desired beeper volume level as the dog becomes accustomed to the beeping sound.

CHARGING THE BATTERIES

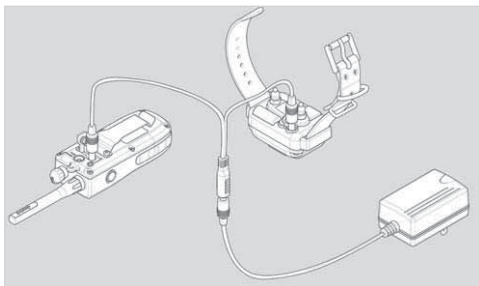

dogtra 2500 T&B Series uses Lithium-Polymer batteries.

1. Charge the unit before using the unit for the first time.
2. Do not charge the batteries near any flammable substances.
3. Fully charge the batteries if the unit is to be stored without use for a period of 3 months or more.

Recharge the unit if :

- The LED indicator light on the collar receiver is emitting a red color.
- If the 3 bar indicator on the transmitter LCD shows just 1 bar.
- The indicator light on the transmitter or receiver will not come on.
- The indicator light on the transmitter or receiver comes on momentarily, but will not stay on when the “Constant” button is pushed.

Battery Charging Procedure

Note : The unit has a partial charge when it leaves the Dogtra facility, upon receipt of the collar, be sure to give it a full 2-hour initial charge before the first use.

1. Attach the charging cables to both the transmitter and receiver(s), as shown on page 38.
2. Plug the charger into a 120-volt wall outlet or, if using the accessory field charger, plug into a cigarette lighter only for Lithium-Polymer battery. (Use a 230-volt European

charger for Europe.) When properly plugged in, all indicator lights should glow red. During the charging process, the unit will shut off. Once the battery cable is unplugged from the unit after a full charge, you will need to turn the unit on again before use.

3. The Lithium-Polymer battery is fully charged within 2 hours. The lights will stay red during the charging process. The red light will change into a steady green light when the battery is fully charged. (When you disconnect the charger after finishing the charge, you will need to restart the units).
4. After charging, cover the battery charging receptacles with the rubber plugs on the transmitter and receiver.

NOTE : Only use Dogtra-approved batteries, chargers, and accessories for your Dogtra e-collars. When a charger is not in use, disconnect it from the power source.

RECEPTION

The **dogtra 2500 T&B Series** collar has a range of 1 mile. Depending on the way you use your transmitter, the transmitter range may vary.

Hold the transmitter away from your body and avoid touching the antenna, to get the greatest range.

For maximum signal strength, keep your unit properly charged.

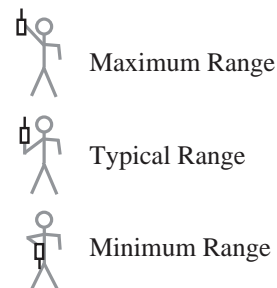

ACCESSORIES

The following items may be purchased separately by calling our customer service at (888) 811-9111. You may also browse the selection at shop.dogtra.com

European Charger

Designed for use with 230V AC electrical outlets in Europe.

Field Auto Charger (for Lithium-Polymer Battery only)

Designed for use with the 10-volt cigarette lighter in your car.

BASIC MAINTENANCE

Be sure that the rubber charging plugs are always secured when the collar is in use. If your plugs break or are ripped, please contact Customer Service at info@dogtra.com or (888) 811-9111 to obtain replacements.

After each session, carefully inspect your unit for any missing parts, or casing damage. Broken casings on either the receiver or transmitter may affect the waterproof guarantee of the unit. The transmitter antenna should be secured and tight for optimum performance. Rinse the unit after each session and clean off any dirt or debris.

Storage Maintenance

Your unit should be fully charged for 2 hours before extended storage. During storage, the unit should be charged every 3 months for 2 hours, and once before the first use.

When traveling, try to store your units in room or slightly warmer temperatures, do not transport the unit exposed in extreme climates.

Troubleshooting :

If you suspect your unit is malfunctioning please refer to the “Troubleshooting Guide” before you send your unit in for service.

If you have any questions or concerns, you may direct your inquiries to info@dogtra.com or call (888) 811-9111.

TROUBLESHOOTING GUIDE

1. My dog is not reacting to the collar.

- Make sure the receiver is turned on. Place the two red dots together to activate the receiver. Push the blue button on the transmitter until it illuminates to activate the transmitter.
- Be sure the collar strap is tight enough so both contact points are touching the dog's skin.
- The contact points may be too short for the dog. To place an order for longer contacts appropriate for your dog, please call (888) 811-9111.

If you are already using the longest contact point available, you might need to trim down the hair on the dog's neck so both contact points are touching the dog's skin.

- The intensity level may be too low for your dog. Keep increasing the stimulation until the dog responds usually by neck movement, head shaking, looking over his shoulder, etc. (response may be very subtle so pay attention.)

2. The test light comes on, but I do not feel any stimulation.

- Your tolerance may be higher than your dog's. You may need to try the unit on your fingertips where sensitivity is higher and/or increase the stimulation level. Be sure both contact points are touching both of your fingertips.
- The battery may be low, check the LED light for battery life.
- If you have a full charge, and you have done all of the above, your unit may need to be serviced. Please contact Customer Service at info@dogtra.com or (888) 811-9111.

3. The transmitter has no range, or stimulation is less when the dog is farther away.

- The antenna(s) may be damaged. To order parts, please contact Customer Service at (888) 811-9111.
- The range indicated on the unit's box is for flat terrain. Heavy brush, trees, hills or moisture will affect the range of your unit. For best range, hold the transmitter vertically above your head, and/or try moving to higher ground.
- Any electrical conductors will affect the range, such as cars, chain-link dog runs, metal buildings and radio towers. For best results, operate away from these structures.

4. My unit is not holding a charge.

- The batteries might not be charged properly, or the charger, splitter and the charging port needs to be looked at. If you suspect your charger/splitter is not functioning properly please contact Customer Service at info@dogtra.com or (888) 811-9111. You can send in your charging units to have us inspect them.
- The charging pin may be damaged. Inside the charging port, there is a metal pin that should be standing straight up and stiff. If the pin is wobbling, broken or missing, you will need to send the unit in to the Repair Dept. The charging port must be clean prior to charging, clean the dirt out with a cotton swab and some rubbing alcohol. If the dog is in salt-water, be sure to rinse the receiver and charging port with clean water.
- For Dogtra units over two years old from the purchase date, the batteries may be replaced. You can replace them yourself by contacting Dogtra. Damages incurred to the unit due to improper battery installation are not covered under any warranty. Battery replacement is the only time customers should open the unit, any other unauthorized servicing or tampering with the unit voids your limited lifetime warranty. If you are still having problems after replacing the batteries, Dogtra strongly recommends sending the unit in for inspection.

WARRANTY AND REPAIR INFORMATION

provides the original purchaser with a **LIMITED LIFETIME WARRANTY**. Limited Lifetime Warranty begins from the date of purchase. For the first two years coverage is for both parts and labor, on all our products purchased new. Accessories such as, chargers, splitter cables, antennas, straps and **batteries** have a one-year warranty from the date of purchase. Once the first and second year warranty coverage expires, the Limited Lifetime Warranty will cover for all parts except accessories and labor fees. Labor fees and shipping fees incurred are the customers' responsibility. Labor fees will be variable depending on the extent of work required. The Limited Lifetime Warranty will expire 5 years from the date a model is discontinued in production by Dogtra Company.

To Qualify for the Limited Lifetime Warranty :

To register your Dogtra product, please log onto our website at www.dogtra.com, click on the warranty registration link and fill out the required information. All registration must be completed within 30 days of your purchase. If you do not have access to a computer, you can call our toll free number of 888-811-9111 so one of our customer service representatives can register your product online for you. Also if you were unable to register your product on our website we will accept all products for repair with a proof of purchase. We strongly recommend you keep your original receipt. If your product is not registered and proof of purchase is not available at the time of service, Dogtra will estimate the age of the unit by the serial number. Serial number estimates can be different than the actual purchase time. Without proof of purchase or product registration this is the only method we have for determining the approximate date of purchase.

Not Covered Under Warranty :

We cannot offer warranty for units/products that have been bought secondhand or as a resold product.

Dogtra **DOES NOT** replace defective units or provide refunds for products purchased from us after 30 days from the date of the purchase. Issues of replacement and refunds on units purchased less than 30 days from an authorized dealer need to be addressed to the dealer directly.

Dogtra's warranty **DOES NOT** cover repairs or replacements due to misuse by the owner or dog, improper maintenance, and/or lost units. Any water damage on the Water Resistant Transmitters of the IQ, 175NCP, 180NCP, 200NCP, 202NCP, 1400NCP, 1402NCP, 1500NCP and 1502NCP will also not be covered. All replacement cost for either the transmitter or receiver will be the owner's responsibility.

*** Battery replacement by the customer during the first year of the warranty is not recommended. If the customer chooses to replace the batteries, any damage to the unit during the change-out by the owner will void the warranty.**

The warranty is void if the unit has been altered or an unauthorized person has attempted repair work.

Procedure for Repair Work :

The cost of shipping products under warranty back to Dogtra is the **customer's responsibility**. Dogtra will provide/pay (via regular ground service, within the continental United States) the shipping cost back to the customer. Any expedited shipping service will be at the customer's expense. Dogtra is not responsible for loss of training time or inconvenience while the unit is in for repair work. **Dogtra does not provide loaner units or any form of compensation during the repair period.**

A copy of the sales receipt showing the purchase date is required before warranty work is initiated.

Please include a brief explanation outlining the problems and include your name, address, city/state/zip code, **daytime phone number, evening phone number, and email address**. Or, you can visit our website at www.dogtra.com. Click on the Service Request Form, print it out and follow the instructions.

If repair costs are not covered under warranty, we will call you for credit card information once the work has been

completed. For any questions concerning your Dogtra products call us Toll Free at 1-888-811-9111, M-F 8:30AM - 4:00PM, Pacific Time, or email us at repair@dogtra.com for specific repair inquiries.

Send repair units to :

Dogtra Company / Repairs
22912 Lockness Avenue
Torrance, CA 90501
U.S.A.

The diagrams and representations in the manual may differ slightly from the actual product depending on the model type.

